

 **Vacmaster**[®]

45L | 1200W
VJH1245PF

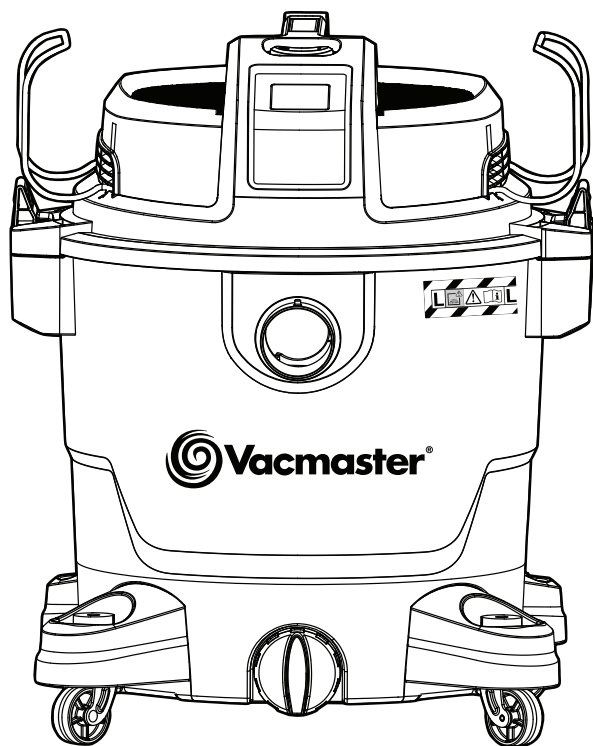

Original Instructions



IPX4 

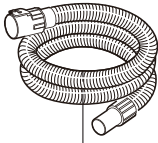
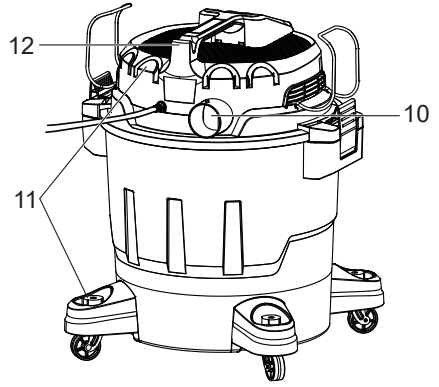
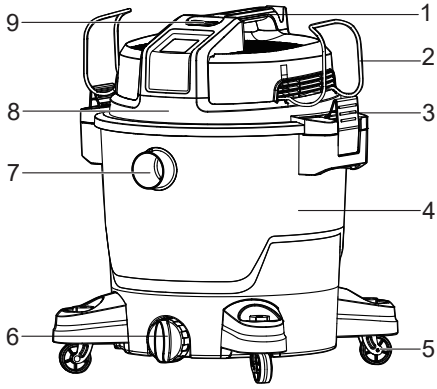

13

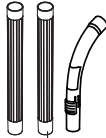

14



15



16



17



18



19



20



21

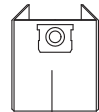

22



23





TABLE OF CONTENTS

SECTION	PAGE
Symbols.....	4
Safety Information.....	5
Unpacking and Checking Carton Contents.....	8
Assembly.....	9
Operation.....	9
Maintenance.....	11
Troubleshooting.....	12
Technical Data.....	13
Recycling and Disposal.....	13

Thank you for purchasing this Vacmaster® wet and dry vacuum cleaner. Feel confident that with Vacmaster® you are obtaining a high-quality product that is engineered for optimal performance. This vacuum cleaner is suitable for use with both liquids and dry materials.

FOR YOUR SAFETY: CAREFULLY READ AND UNDERSTAND ALL INSTRUCTIONS.

SYMBOLS

	Caution
	Read operator's manual.
	Appliance in which protection against electric shock does not rely on basic insulation only but in which additional safety precautions are provided, such as double insulation or reinforced insulation, there being no provision for protective earthing or reliance upon installation conditions.
	Vacuum cleaners of dust category L according to IEC/EN 60335-2-69 for dry vacuuming of materials with an exposition limit value $> 1\text{mg}/\text{m}^3$ that are hazardous to one's health.
	WARNING: The vacuum cleaner may contain materials that are hazardous to one's health. Have the emptying and maintenance, incl. the disposal of dust-collection container, carried out by a specialist. Appropriate protective equipment is required. Do not operate the vacuum cleaner without the complete filter system. Otherwise there is danger to your own health.

SAFETY INFORMATION

READ AND UNDERSTAND ALL INSTRUCTIONS BEFORE USING THIS VACUUM CLEANER.

This machine is intended for commercial use, for example in hotels, schools, hospitals, factories, shops, offices and rental businesses. Any other use is considered as improper use. The manufacturer accepts no liability for any damage resulting from improper use. The risk for such improper use is borne solely by the user.

When using the equipment, a few safety precautions must be observed to avoid injuries and damage. Please read the complete operating manual with due care. Keep this manual in a safe place so that the information is always available. If you give the equipment to any other person, give them these operating instructions as well. We cannot accept any liability for damage or accidents which arise due to a failure to follow these instructions and the safety information.

- Never leave the appliance switched on unattended, if you leave the work area, switch the appliance off or unplug it from the power supply.
- Do not vacuum or use this vacuum cleaner near flammable liquids, gases or explosive vapours like gasoline or other fuels, lighter fluids, cleaners, oil-based paints, natural gas, hydrogen, or explosive dusts like coal dust, magnesium dust, grain dust or gun powder. Sparks inside the motor can ignite flammable vapours or dust.
- This vacuum cleaner is not suitable for the vacuuming of asbestos or asbestos dust.
- Do not vacuum anything that is burning or smoking, such as cigarettes, matches, or hot ashes.
- Ensure the hose and connections are always pointed away from the users face, hair, ears and eyes during operation and never direct the nozzle towards persons or animals.

- Clear the working area of any items or possessions that you do not wish to be vacuumed before operation.
- Keep cord away from heated surfaces.
- Do not expose to rain. Store indoors.
- Do not unplug by pulling on the cord. To unplug, grasp the plug, not the cord.
- Do not use with damaged cord, plug or other parts.
- Do not pull or carry by cord, use cord as handle, close a door on cord, or pull cord around sharp edges or corners.
- Do not handle the plug or vacuum cleaner with wet hands.
- To reduce the risk of health hazards from vapours or dusts, do not vacuum toxic materials.
- Frequently check that the float valve positioned underneath the motor is able to move freely.
- Do not use this vacuum cleaner with a torn filter or without the filter installed.
- Do not allow to be used as a toy. Close attention is necessary when used by or near children.
- To reduce the risk of injury from accidental starting, unplug power cord before changing or cleaning filter.
- Unplug from power supply when not in use and before carrying out maintenance.
- Do not cover the ventilation openings. Do not vacuum with any ventilation openings blocked; keep free of dust, lint, hair or anything that may reduce air flow.
- Keep hair, loose clothing, fingers, all parts of body away from openings and moving parts.
- If the supply cord is damaged, it must be replaced by the manufacturer, a qualified service agent or similarly qualified persons in order to avoid a hazard.
- This appliance can be used by children aged from 8 years and above and persons with reduced physical, sensory or mental capabilities or lack of experience and knowledge if they have been given supervision or instruction concerning use of the appliance in a safe way and understand the hazards involved.
- Children shall not play with the appliance.

- For additional protection: It is recommended that this vacuum cleaner can be used in conjunction with residual current device (RCD) with a rated residual current of 30mA or less.
- If foam or liquid escapes from the machine, switch off immediately.
- Clean the float valve regularly and examine it for signs of damage.
- Precautions should be taken when changing attachments.
- For user servicing, the machine must be dismantled, cleaned and serviced, as far as is reasonably practicable, without causing risk to the maintenance staff and others. Suitable precautions include decontamination before dismantling, provision for local filtered exhaust ventilation where the machine is dismantled, cleaning of the maintenance area and suitable personal protection.
- Perform a technical inspection at least annually, consisting of, for example, inspection of filters for damage, air tightness of the machine and proper function of the control mechanism.
- Besides the operating instructions and the binding accident prevention regulations valid in the country of use, observe recognized regulations for safety and proper use.
- When dust removers are used, the rate at which air is exchanged in the room must be adequate if the exhaust air from the vacuum cleaner is blown into the room (please observe regulations valid in your country).
- Before starting work, the operating staff must be informed on
 - use of the vacuum cleaner
 - risks associated with the material to be picked up
 - safe disposal of the picked up material.
- Before transporting the collection tank, close all the locks. Do not tilt the cleaner if there is liquid in the collection tank. Do not use a crane hook to lift the cleaner.
- When using an extension lead, check the minimum cross-sections of the cable:

Cable length	Cross section	
	< 16 A	< 25 A
up to 20 m	1.5 mm ²	2.5 mm ²
20 to 50 m	2.5 mm ²	4.0 mm ²

⚠ WARNING: When carrying out service or repair operations, all contaminated items which cannot be satisfactorily cleaned are to be disposed of; such items shall be disposed of in impervious bags in accordance with any current regulation for the disposal of such waste.

When using as blower:

- Direct air discharge only at work area.
- Do not use Wet/Dry Vacuum as a sprayer.
- Do not direct air at bystanders.
- Keep children away when blowing.
- Wear safety goggles.

UNPACKING AND CHECKING CARTON CONTENTS

1	Carry Handle	9	On/Off Switch	17	Utility Nozzle
2	Hose Storage Rack	10	Blowing Port	18	Round Dust Brush
3	Latch	11	Accessory Storage	19	Cartridge Filter (pre-installed)
4	Container	12	Power Cord Storage Hook	20	Foam Filter
5	Caster	13	Suction Hose	21	Screw (x4)
6	Drainage Port	14	Extension Wand (x3)	22	Dust Bag
7	Suction Port	15	Floor Nozzle	23	Instruction Manual
8	Power Head	16	Crevice Tool		

ASSEMBLY

NOTE: A Phillips screwdriver is required. 

1. Remove all the contents from inside of the vacuum cleaner container.
2. Turn the container upside down and insert the feet with casters into the slots and apply pressure until they click into place. Secure them with supplied screws (Fig. 1).
3. Your vacuum cleaner comes ready for dry vacuum cleaning with the cartridge filter pre-installed. If the cartridge filter is not installed, refer to page 12.
4. Optionally, for improved dust filtration and hygienic disposal, fully fit the dust bag flange onto the inlet stub (Fig. 2).

NOTE: The dust bag is for dry pick-up only.

5. For wet vacuum cleaning, replace the cartridge filter with the foam filter supplied. Do not use a dust bag when wet vacuuming. If the foam filter is not installed, refer to page 12.
6. Secure the power head back on the container using the latches.
7. Insert the locking end of the hose into the suction port of the container and turn clockwise to lock into place (Fig. 3).
8. Choose the desired accessories and/or extension wands and push fit onto the hose nozzle (Fig. 4).

OPERATION

1. Switching On/Off

Connect the mains plug to a suitable power outlet.

Position	Status
I	on
O	off



2. Wet & Dry Vacuum Operation



WARNING: ENSURE YOU READ, UNDERSTAND AND APPLY SECTION ENTITLED 'SAFETY INFORMATION'.

- 1) Verify that the correct filter is installed for wet or dry vacuuming and the container latches are secured.
- 2) Secure the locking end of the suction hose into the vacuum suction port.
- 3) Push the desired accessories onto the hose nozzle. The air flow regulation allows you to change vacuum cleaner suction. For best cleaning results, fully close the air flow regulation (Fig. 5).
- 4) Plug the power cord into a power outlet.
- 5) Turn on the motor by assigning the switch to the "I" ON position.
- 6) Once you have completed vacuuming, switch to the "O" OFF position and unplug the power cord from the power outlet.

For Dry Vacuuming:

 **WARNING: BEFORE INSTALLING, REMOVING OR CLEANING THE VACUUM CLEANER FILTER, ENSURE THAT THE POWER CORD IS UNPLUGGED AND SWITCHED OFF.**

- 1) To prepare your vacuum cleaner for dry vacuuming, install the cartridge filter over the filter cage with the flat end of the filter towards the vacuum power head. Carefully push the filter until it sits flush forming a tight seal.
- 2) Place the filter retainer on top of cartridge filter over the raised lip and tighten the retainer lock clockwise to secure against the internal filter cage (Fig. 6).
- 3) Optionally, fully fit the dust bag flange onto the inlet stub. The vacuum cleaner can be used with or without dust bags.

IMPORTANT! Check the filter regularly for optimal performance. An old or blocked filter will reduce suction performance.

For Wet Vacuuming:

- 1) To prepare your vacuum cleaner for wet vacuuming, remove the filter retainer and the dry use cartridge filter.
- 2) Carefully install the supplied foam filter over the internal filter cage, making sure the whole cage is covered (Fig. 7).

 **WARNING: DO NOT USE THE CARTRIDGE FILTER OR DUST BAG FOR WET VACUUMING.**

IMPORTANT! When vacuuming large quantities of liquids, do not immerse the nozzle completely; leave a gap at the tip of the nozzle to allow air inflow. The vacuum cleaner is fitted with a float valve (①) that stops the suction action when the container reaches its maximum capacity (Fig. 8). You will notice an increase in motor noise. When this happens, turn off the machine, disconnect from power supply, and drain the liquid. To continue vacuuming, replace the drainage cap. After wet vacuuming, empty the container, clean and dry inside before storage.

3. Blower Operation

 **WARNING: KEEP BYSTANDERS CLEAR FROM BLOWING DEBRIS.**

 **WARNING: ONLY WORK WITH A CLEAN SUCTION HOSE. DO NOT USE THE BLOWER FUNCTION IN AN ENCLOSED SPACE OR FOR DUSTS WHICH ARE HAZARDOUS TO HEALTH. DO NOT INHALE DUSTS. DO WEAR A DUST MASK IF BLOWING CREATES DUST THAT MIGHT BE INHALED.**

 **WARNING: ONLY USE THE BLOWING FUNCTION FOR CLEANING, REMOVING DUST, OR DRYING MACHINES AND APPLIANCES.**

- 1) Make sure the container and any collected waste is emptied before using as a blower. This also includes removal of the dust bag.
- 2) Insert the locking end of the hose into the blowing port on the rear of the power head (Fig. 9).
- 3) Turn on the motor on by turning the switch to the 'I' ON position.

MAINTENANCE



WARNING: REMOVE THE POWER CORD FROM THE POWER SUPPLY BEFORE CARRYING OUT ANY MAINTENANCE.

- 1) Keep all safety devices, air vents and the motor housing free of dirt and dust. Use a soft, dry brush to clean the equipment regularly.
- 2) Clear all dirt or debris from the collection tank after each use. Allow to dry before replacing the power head. Do not use cleaning agents or solvents; these may damage the appliance.
- 3) Check the hose, attachments, and power cord to verify that they have not been damaged or any debris is trapped and blocking airflow.

1. Cleaning Cartridge Filter

Remove the filter and clean by gently tapping or brushing off dirt. For optimal performance it is recommended to replace the old filter with a new filter regularly.

2. Cleaning Foam Filter

Remove the foam filter and use a mild soap and water solution to wash and rinse with clean water (Fig. 10). Allow the filter to air dry completely before storing or re-installing.

TROUBLESHOOTING



WARNING: TO REDUCE THE RISK OF ELECTRIC SHOCK-UNPLUG BEFORE TROUBLESHOOTING.

Cleaning Performance

Vacmaster vacuum cleaners are tested for endurance. If your motor is operating, then the most likely cause for a loss in suction is a blockage or an opening in the vacuum.

To maintain a high cleaning performance from your machine, it is important to replace or clean cartridge filters as necessary. Replace full dust bags to prevent performance drops. A performance drop with clean filters can only be caused by a blockage in the tools or the hose.

PROBLEM	POSSIBLE CAUSE	SOLUTION
The appliance does not work.	No power.	Check the power supply and fuse.
	Functional fault in the power cord, switch, or motor.	Have the damaged part checked by qualified personnel or contact the after sales helpline.
Dust is escaping from the motor cover.	The cartridge filter is missing or damaged.	Check the cartridge filter is fitted and the condition of it. Replace if necessary.
	Misuse the cartridge filter when wet vacuuming, causing the damage of cartridge filter.	Replace the damaged cartridge filter with a new one when dry vacuuming.
	Misuse the foam filter when dry vacuuming.	Replace the foam filter with the cartridge filter.
Low suction power and high operating noise / vibrations.	Dust bag is full.	Replace the dust bag.
	Suction nozzle, hose, or tank inlet is blocked.	Check the suction nozzle, hose, and tank inlet for obstructions.
	Cartridge filter is blocked.	Remove the cartridge filter and clean.
	Float valve has closed.	Empty the container of any liquid waste and ensure the float valve located underneath the filter is able to move freely.

TECHNICAL DATA

Model Number	VJH1245PF
Motor	220-240V~50Hz
Power Input	1200W
Tank Volume	45L
Net Weight	9.2kg
Max. Vacuum Pressure	17kPa / 170hPa
Max. Flow Rate	41L/s / 147.6m ³ /h
Sound Pressure Level (L _{PA})	78dB(A) K=2dB
Vibration	a _n <2.5m/s ² K=1.5m/s ²

RECYCLING AND DISPOSAL



This marking indicates that this product should not be disposed with other household wastes. The machine must be delivered in rigid packaging to avoid damage during transportation.



The packaging and the machine itself are manufactured from recyclable materials and should be disposed of accordingly.

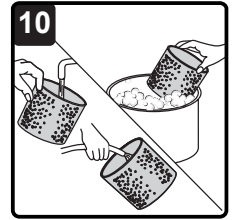
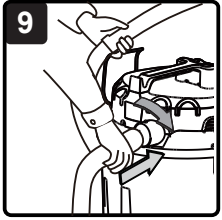
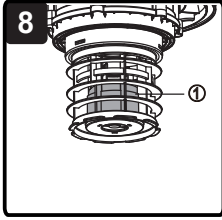
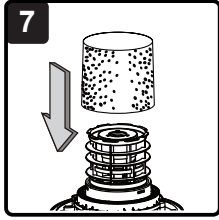
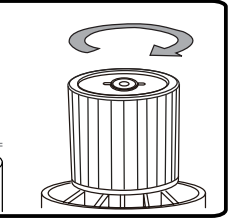
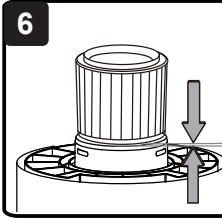
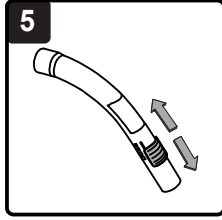
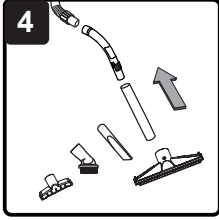
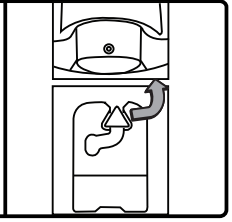
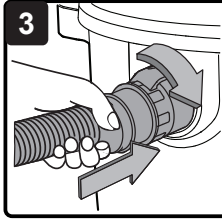
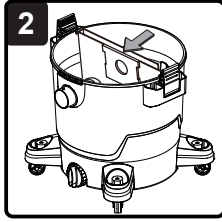
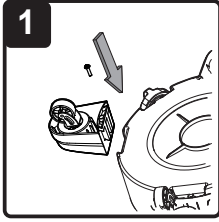



FSC

www.fsc.org

RECYCLED

Paper made from
recycled material

FSC™ C140878

VJH1245PF
12, SHALIN BUNGLOWS,
B/H KARMAJYOT BUNGLOWS,
NR.S.P RING ROAD, SHILAJ, AHMEDABAD,
GUJARAT, 380058